

## MOTOR DE ARRANQUE

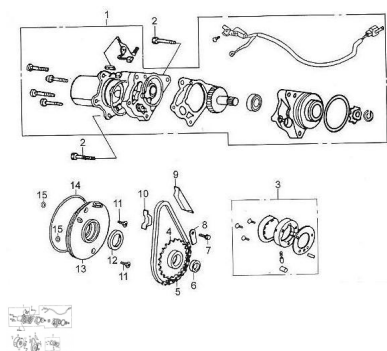

Rating: Not Rated Yet

**Price:**

Variant price modifier:

Base price with tax:

Price with discount:

Salesprice with discount:

Sales price:

Sales price without tax:

Discount:

Tax amount:

[Ask a question about this product](#)

### Description

Ref.	Título	Código
1	CONJUNTO MOTOE DE ARRANQUE	89-82200-G011
2	TORNILLO M6X50	89-B1667400-6
3	EMBRAGUE DE ARRANQUE	89-21300-G011
4	CORONA PRIMARIA	89-2142A-G011
5	CADENA ENCENDIDO ACCIONADO POR MOTOR	89-2141B-G011
6	O-RING 19X30X5	89-90309-D002
7	TORNILLO M6X10	89-B1667400-7
8	CHAVETA	89-21407-G011
9	PLATO GUÍA CADENA	89-2144B-G011
10	PLATO PROTECTOR DE CADENA	89-2143B-G011
11	TORNILLO M6X16	89-B008190106
12	RETEN 30X42X4.5	89-90308-D002
13	DISCO	89-21406-G011
14	O-RING 106.8X2	89-90115-G011
15	O-RING 6X1.8	89-90110-D002

