

ARRANQUE ELECTRICO

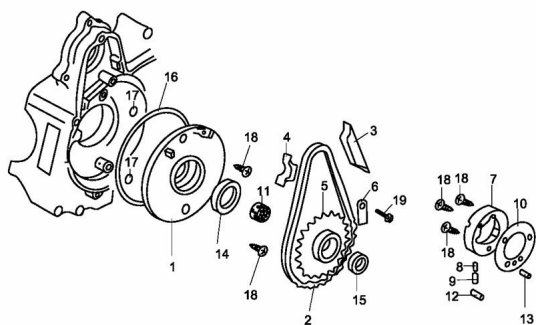

Rating: Not Rated Yet

Price:

Variant price modifier:

Base price with tax:

Price with discount:

Salesprice with discount:

Sales price:

Sales price without tax:

Discount:

Tax amount:

[Ask a question about this product](#)

Description	Ref.	Título	Código
	1	DISCO SE PARADOR DE ACEITE FX110,ZB	
	2	CADENA DE	
	3	PLACA GUIA DE CADENA	
	4	PLACA DE	

Ref.	Título	Código	
	5		
	6	PLACA DE CADENA	
	7		
	8	RODILLO DE EMBRAQUE DE RESORTE	
	9	ESPINA DE RESORTE	
	10	PLACA LATERAL DE EMBRAQUE	
	11	COLLAR	
	12	RODILLO DE EMBRAQUE 10X10	
	13	ESPINA 5X11.8	
	14	SELLO DE ACEITE 30X42X45	
	15	SELLO DE ACEITE	
	16	O-RING 106X2	
	17	O-RING 6.58X1.8	
	18	TORNILLO 6X16	
	19	TORNILLO 6x10	

